

# Installation Manual



## **BASIC** **IN-CAB CONTROL KIT**

**w/ 325 SERIES AIR COMPRESSOR**

*(for vehicles with a preexisting air system)*

**10281\***     **SIMULTANEOUS ACTIVATION**  
Paddle Valve w/ Digital Gauge

**10272\*\***     **INDEPENDENT ACTIVATION**  
Paddle Valve w/ Digital Gauge

**Thank you & congratulations on the purchase of a Basic In-Cab Control Kit with simultaneous or independent air spring activation via a Digital Paddle Valve switch.**

- This Basic Kit is for vehicles with a pre-existing onboard air system. Premium kits are available for those without an existing air system on their vehicle.
- **Simultaneous Kits\* (10281)** are designed to fill and exhaust both air springs to the same pressure simultaneously.
- **Independent Kits (10272)** are designed to fill and exhaust each air spring independently to its own pressure.
- *Air Spring Kit sold separately.*

**\*IMPORTANT**

This kit is not recommended for vehicles carrying slide in campers or other loads which the load is above the cab. Air spring inflation kits that simultaneously fill both air springs through one supply / discharge line do not prevent air transfer from one air spring to the other when cornering.

*If this is a concern to the customer, contact Customer Service at 800.663.0096 for an **Independent Air Spring Inflation Kit** option.*

.....

**BEFORE STARTING THE INSTALLATION:**

1. Read through this manual and ensure you can complete the installation once started.
2. Ensure the kit you received contains all the items shown in the kit layout photo on the following page.
3. It is recommended to use a good quality anti-seize on all fasteners. This will reduce the chance of corrosion on the fasteners and will help facilitate removal, if required at a later date.

**PLEASE NOTE:**

***This kit contains push-to-connect fittings; using scissors or wire cutters to cut the nylon airline will distort the line and cause the connection to leak. THE AIRLINE MUST BE CUT OFF SQUARELY WITH THE NYLON HOSE CUTTER PROVIDED IN THIS KIT OR A SHARP UTILITY KNIFE.***

**KIT CONTENTS / LAYOUTS**

**BASIC KITS:** for those with a pre-existing air system on their vehicle.

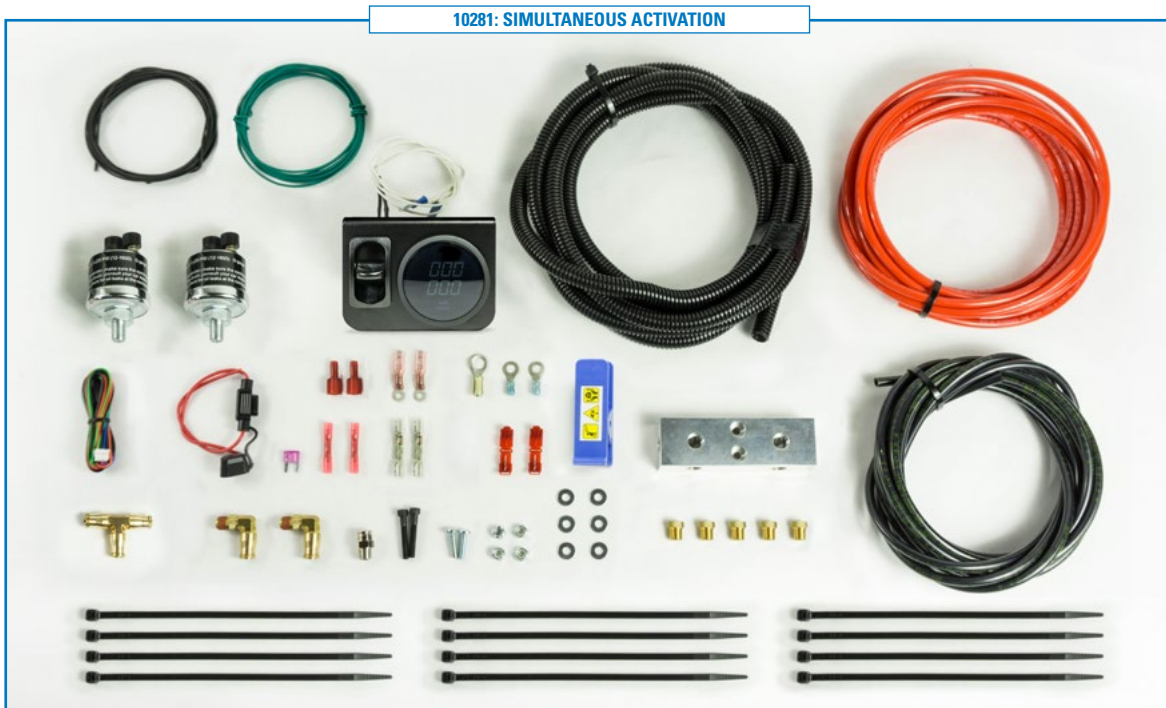

## 1 ASSEMBLY PREPARATION

Install the air spring assemblies (if not previously installed).

Follow the instructions provided within the air spring kit – with the exception of the airline routing.

## 2 ASSEMBLE & MOUNT THE MANIFOLD



**CAUTION:** The manifold utilizes NPT fittings. Finger tighten the fittings and turn an extra 1.5-3.0 turns to tighten the fittings. Never back off an installed NPT fitting as it will corrupt the seal and contribute to leakage and failure.

**NOTE:** Apply thread sealant or Teflon tape to all the fitting threads installed into the manifold to prevent air leaks.

If a simultaneous kit (10281) is being installed, is being installed, complete Step 2A and then proceed onto Step 3.

If an independent kit (10272) is being installed, skip Step 2A, complete Step 2B and then proceed onto Step 3.

### 2A SIMULTANEOUS AIR SPRING ACTIVATION MANIFOLD ASSEMBLY (10281 KITS ONLY)

Install the pressure sensor into the top port of the manifold.

Install two 1/8" 90° air fittings into the side ports.

Provided in the kit are five 1/8" brass plugs. Install them into the remaining ports of the manifold as shown in Figure 2A.

### 2B INDEPENDENT AIR SPRING ACTIVATION MANIFOLD ASSEMBLY (10272 KITS ONLY)

Install the pressure sensors into the top ports of the manifold as shown in Figure 2B.

Install four 1/8" 90° air fittings into the manifold.

Install two 1/8" brass plugs into the remaining ports.

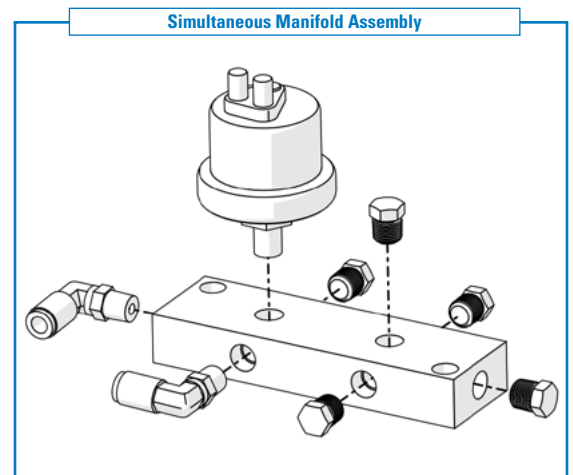

2A

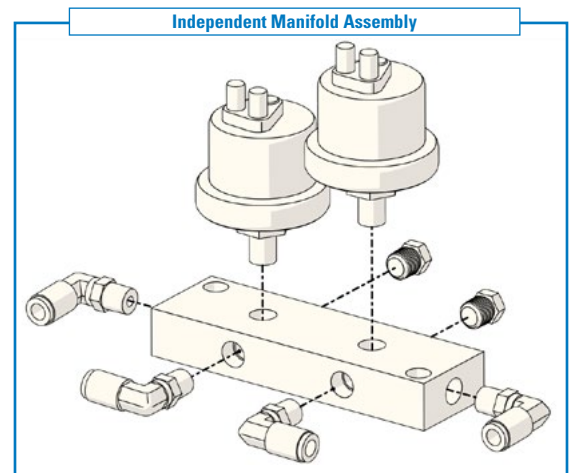

2B

### 3 MOUNT THE MANIFOLD

Choose a location on the frame to mount the manifold. Preferably near the air springs and away from any debris, moving components or heat sources.

**NOTE: The manifold must be mounted in a location where a 12 ft length of wire can reach the manifold from the pressure gauge.**

Using the manifold as a template, mark and drill two 13/64" holes.

Secure the manifold to the chosen location using two #10-32 x 1 1/4" socket head cap screws, two #10 flat washers, and two #10 nyloc nuts.

### 4 AIRLINE CONNECTIONS

**NOTE: Before cutting the airline, ensure that there's enough red and black airline to complete the following steps. Adjust the manifold, compressor, relay, or gauge mounting locations if there is not enough airline.**

**If a simultaneous kit (10281) is being installed**, complete Step 4A and then proceed to Step 5.

**If an independent kit (10272) is being installed**, skip Step 4A, complete Step 4B (on the following page), and then proceed to Step 5.

#### 4A SIMULTANEOUS AIR SPRING ACTIVATION AIRLINE CONNECTIONS (10281 KITS ONLY)

**Refer to the wiring and plumbing diagram on Page 12 for the following instructions:**

Install the paddle switch into the supplied control panel bracket. The switch must be installed such that the delivery (DEL) port is above the supply (SUP) port.

Connect one end of the red airline to the paddle switch port marked "DEL".

Connect one end of the black airline to the paddle switch port marked "SUP".

Route the other end of both the red and black airlines through the firewall boot and into the engine compartment.

*...Step continues on the following page*

Route the black airline to the air source (compressor / tank), cut it to length and use the provided tube fittings to connect it to the outlet of the air source.

Route the red airline to the manifold, cut it to length, and connect it to the air fitting on the manifold.

Attach the remaining red airline to the air fitting on the manifold and route it near the air springs.

Attach the remaining red airline to the air fitting on the manifold and route it near the air springs.

The red airline is connected to both air springs using the supplied tee fitting.

Use the tie straps provided in the kit to secure all the airlines away from any moving components, debris, or heat sources.

#### **4B INDEPENDENT AIR SPRING ACTIVATION AIRLINE CONNECTIONS (10272 KITS ONLY)**

***Refer to the wiring and plumbing diagram on Page 13 for the following instructions:***

Install both paddle switches into the supplied control panel bracket. The switches must be installed such that the delivery (DEL) port is above the supply (SUP) port.

Locate the 30 ft. length of black airline and connect it to one of the paddle switch ports marked "SUP".

Locate the 50 ft. length of red airline and connect it to one of the of the paddle switch ports marked "DEL"

Route both red and black airlines through the firewall and into the engine bay.

Route the black airline to the air source (compressor / tank), cut it to length and use the provided tee fittings to connect it to the outlet of the air source.

Route the red airline to where the manifold was installed.

Cut the airline to length and connect it to one of the air fittings on the manifold *(as shown in the diagram on Page 13)*.

*...Step continues on the following page*

Connect the remaining black airline to the to the other paddle switch port marked "SUP"

Connect the remaining red airline to the other paddle switch port marked "DEL"

Route both red and black airlines through the firewall and into the engine bay.

Route the black airline to the air source (compressor / tank), cut it to length and connect it to the tee fitting on the outlet of the air source.

Route the red airline to the manifold and connect it to the air fitting on the manifold *(as shown on the diagram on Page 13)*.

Use the remaining red airline to connect the air fittings on the manifold to each air spring.

**NOTE: In order to ensure that the system operates correctly it is imperative that the red airline attached to the left paddle switch is connected to the air fitting that supplies air to the left air spring, and vice versa for the other side. See the diagram on Page 13.**

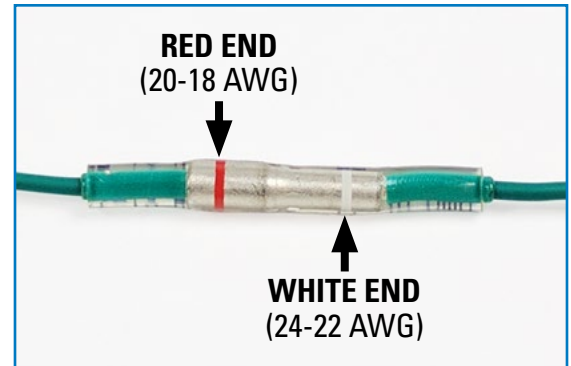

5

## 5 GAUGE HARNESS CONNECTIONS

**If a simultaneous kit (10281) is being installed,** complete Step 5A then proceed to Step 6.

**If an independent kit (10272) is being installed,** skip Step 5A, and complete Step 5B (on the following page) then proceed to Step 6.

### 5A SIMULTANEOUS AIR SPRING ACTIVATION GAUGE HARNESS CONNECTIONS (10281 KITS ONLY)

**Refer to the Wiring Diagram on Page 12:**

Install the pressure gauge into the control panel bracket.

Insert the supplied gauge harness into the back of it. *(Refer to Figure 7 on Page 10)*.

Locate two black wires and one blue wire attached to the pressure gauge wiring harness. Insert all three wires into one end of the red heat shrinkable butt connector. Insert the supplied 20 AWG black wire into the other end. Crimp and apply heat to both ends to create a sealed connection.

*...Step continues on the following page*



Route the 20 AWG black wire to the pressure sensor that was attached to the manifold (*in Step 2*).

Crimp a red heat shrinkable ring terminal to the end of the 20 AWG black wire. Apply heat to the terminal to create a sealed connection.

Attach the ring terminal to the 'M' post of the pressure sensor.

Torque the knob to 0.1 N•m (0.9 lbf - in).



**CAUTION:** Over torquing the knob can cause it to break and thus void the warranty.

Locate the green wire on the pressure gauge wiring harness and insert it into the white end of the clear heat shrinkable butt connector.

Insert the supplied 20 AWG green wire into the red end of the connector. Crimp and heat both ends (*see Figure 5 on previous page*).

Crimp a red heat shrinkable ring terminal to the end of the green wire. Apply heat to the terminal to create a sealed connection.

Attach the ring terminal to the 'G' post of the pressure sensor.

Torque the knob to 0.1 N•m (0.9 lbf - in).



**CAUTION:** Over torquing the knob can cause it to break and thus void the warranty.

Use the supplied loom to cover the exposed wires.

## 5B INDEPENDENT AIR SPRING ACTIVATION GAUGE HARNESS CONNECTIONS (10272 KITS ONLY)

**Refer to the Wiring Diagram on Page 13:**

Install the pressure gauge into the panel control bracket. Insert the supplied gauge harness into the back of it. (*Refer to Figure 7 on Page 10*).

The wires on the gauge harness need to be extended in order to reach the pressure sensors on the manifold.

Locate the blue, green and two black wires on the gauge wiring harness.

Provided in the kit are four clear heat shrink butt connectors, and 12 ft of black, green, and blue 20 AWG wire.

*...Step continues on the following page*



Insert the green wire on the pressure gauge wiring harness into the white end of the clear heat shrinkable butt connector. Insert the supplied 20 AWG green wire into the red end of the connector. Crimp and heat both ends to create a sealed connection (*see Figure 5 on Page 7*).

Repeat this step for the two black wires and one blue wire on the wiring harness.

Crimp a red heat shrinkable ring terminal to the end of each wire that was extended. Heat the connector to create a sealed connection.

Use the supplied loom to cover the exposed wires and route the wires to the pressure sensor on the manifold.

Attach each ring terminal to the pressure sensors (*as shown in the diagram on Page 13*).

Torque each of the knobs on the pressure sensor to 0.1 N.m (0.9 lbf-in) to secure the ring terminal in place.



**CAUTION:** Over torquing the knob can cause it to break and thus void the warranty.

Use the supplied loom to cover the exposed wires.

## 6 GAUGE HARNESS CONNECTIONS CONTINUED

Locate the red wire on the pressure gauge wiring harness and insert it into the white end of the clear heat shrinkable butt connector. Insert a fuse holder into the red end of the connector. Crimp and heat both ends. Insert a 3 amp fuse into the fuse holder.

Attach a red spade terminal to the free end of the fuse holder. Use a red T-tap connector to connect to the 12 VDC switched ignition.

*(Optional)* Connect the orange wire to the headlight switch for auto dimming of the gauge.

Use a blue ring terminal to connect the white wires from each paddle switch to the ground.

**NOTE:** *These white wires are for an optional circuit to enable the compressor when inflating the air spring. As your onboard air system was previously installed they do not need to be connected and are thus going to the ground. If you would like to add this option contact customer service for further information.*

*...Step continues on the following page*

Use a blue ring terminal to connect one black wire from the gauge harness to the ground.

**NOTE: If additional wire is needed use 24-20 AWG wire to extend the wiring harness.**

## 7 MOUNT THE CONTROL PANEL

The control panel consists of a digital air gauge, paddle switch(es), control panel bracket and its associated fasteners.

Mount the gauge (*according to the Figure 10 below*). Use two #10 Phillips head screws, four flat washers and two nuts to secure the control panel to the chosen mounting location.

**NOTE: When installing the gauge cover ensure that the flat face is flush against the bracket.**

**NOTE: If you do not wish to use the gauge cover assemble the kit according to Option 1.**

**If glare is affecting the legibility of the digital gauge, assemble the kit according to Option 2 (see Figure 10).**

**The installation for this kit is complete. Proceed to the next page to test the system.**

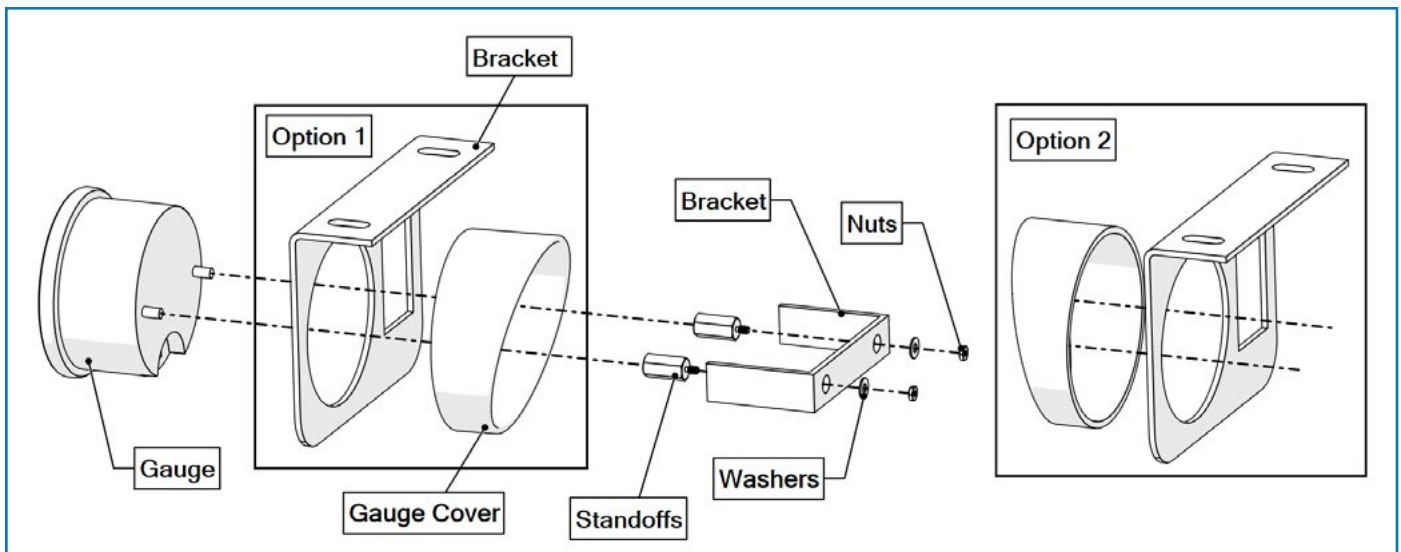

## 8 TESTING THE SYSTEM

Turn the ignition ON, move the paddle switch to the UP position. The gauge should show air pressure being delivered to the air springs raising the vehicle.

Then move the paddle switch to the lower position. The gauge should show the air pressure dropping and lowering the vehicle.

If the pressure gauge cannot read the pressure sensor signal the gauge will count down to "0" and begin flashing. Check to ensure that the system is wired correctly.

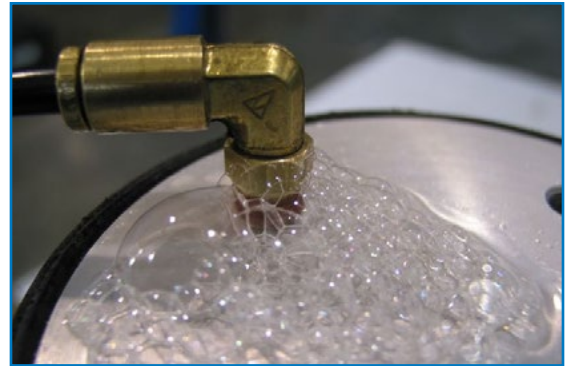

9

## 9 AIR LEAK CHECK

Inflate both the air springs to 90 PSI. Use a dish soap and water mixture on all airline connections to detect air leaks. Repair as necessary and retest. Inflate the air springs to a predetermined value and then the following day recheck the pressure. If one or both of the air springs have lost pressure, a leak is present. The leak must be repaired and then retest the vehicle until no leaks exist.

***DO NOT EXCEED 100 PSI TO THE AIR SPRINGS AT ANY TIME***

.....

## OPERATING YOUR VEHICLE WITH AIR SUSPENSION

Air springs have minimum and maximum pressure requirements. Never operate your vehicle with less than 10 psi in air spring and never inflate air springs over 100 psi. Damage to air springs will result.

Check air pressure in air springs daily for first couple of days to ensure a leak has not developed. Air springs are designed to maintain the vehicles stock ride height with a load. Do not use the air springs as a means to lift vehicle with no load. This will result in a harsh ride.

## SERVICING YOUR VEHICLE WITH AIR SUSPENSION

When lifting the vehicle with a floor jack or hoist on the frame, never allow the air spring to limit the travel of the axle. Try to always jack the vehicle on the axle. Suspending the axle with the air spring limiting the axle travel will damage the air spring and void the air spring warranty.

## WARRANTY

To be eligible for warranty, the owner must submit their warranty card or register online within 30 days of the purchase date.

***NOTE: The owner's warranty will be void if air springs are run with less than the minimum of 10 psi.***

.....

**WIRING & PLUMBING DIAGRAM**

**SIMULTANEOUS AIR SPRING ACTIVATION (10281 KITS)**

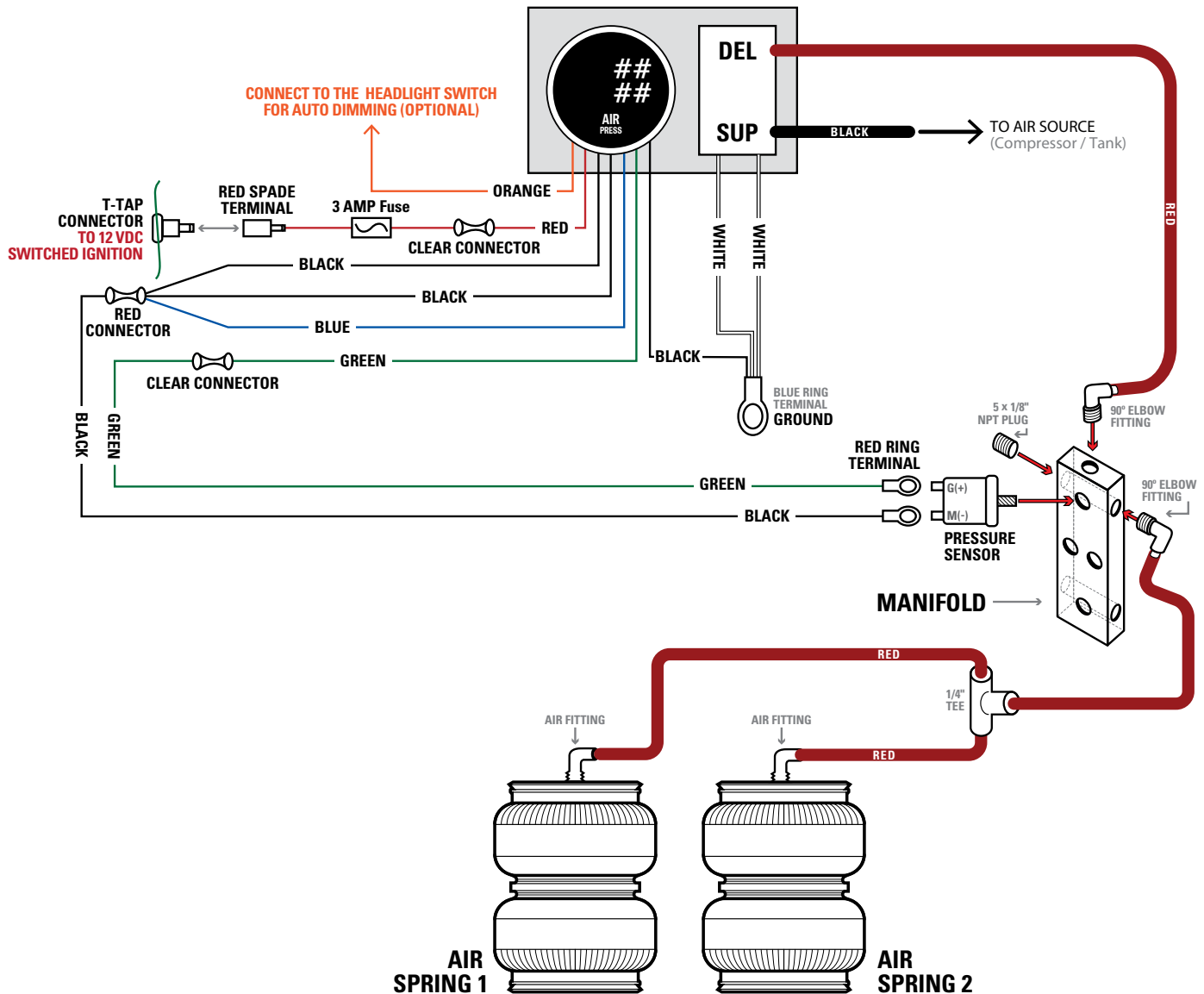

**NOTE:**

The white wires on the paddle switch are for an optional circuit to enable the compressor when inflating the air spring. As your onboard air system was previously installed they do not need to be connected. If you would like this option contact customer support for further information at 800.663.0096.

**WIRING & PLUMBING DIAGRAM**

**INDEPENDENT AIR SPRING ACTIVATION (10272 KITS)**

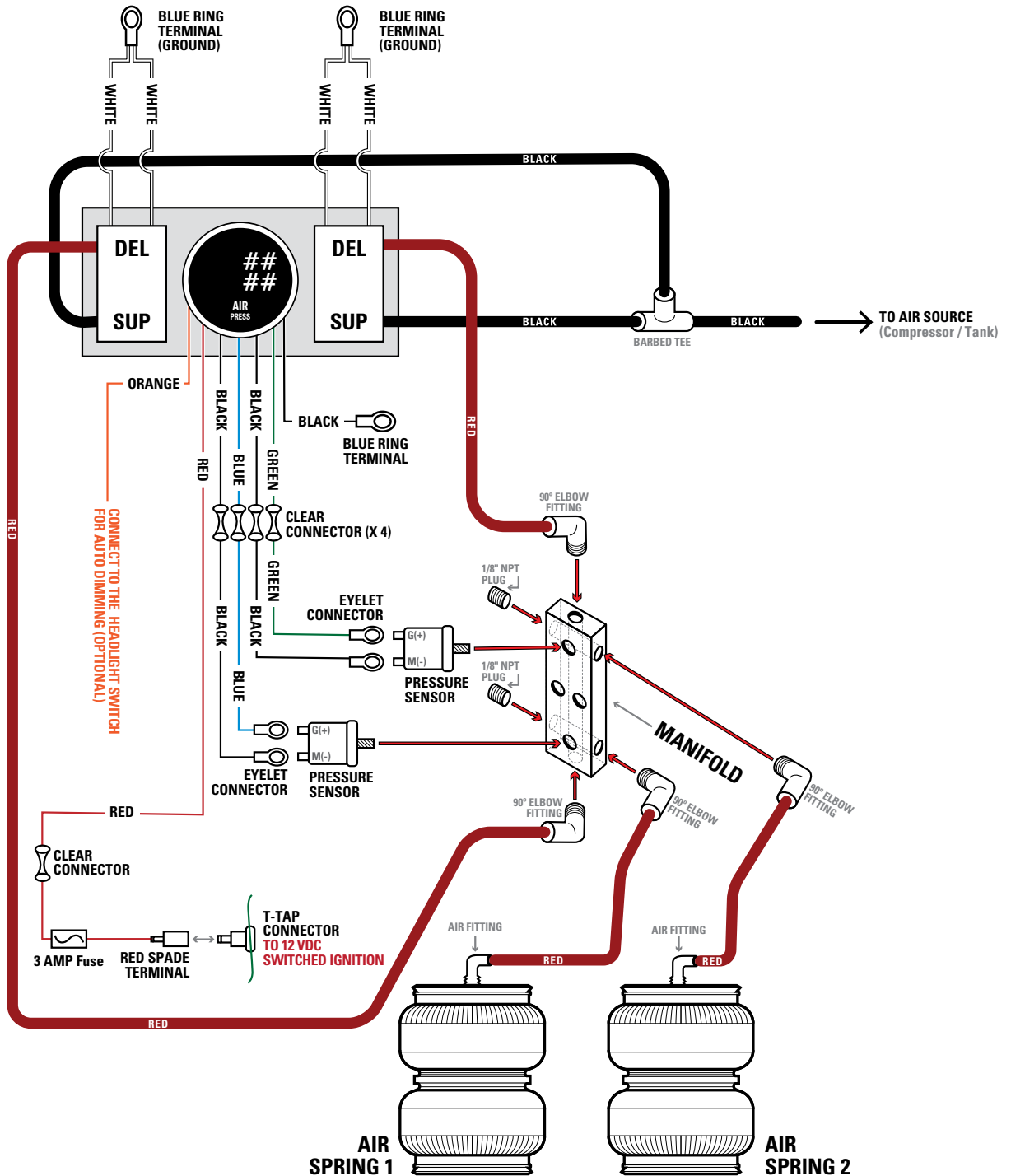

**NOTE:**

The white wires on the paddle switch are for an optional circuit to enable the compressor when inflating the air spring. As your onboard air system was previously installed they do not need to be connected. If you would like this option contact customer support for further information at 800.663.0096.